

Glenfield

Water engineers to the world

Series 641/03 (5000) PN 25, Swing Check Valve, 350mm and above

Use	
For water and neutral liquids to max. 70°C	

Tests	
Hydraulic tests:	Body: 1.5 x PN
Seat:	1.1 x PN

Optional Extras	
Lever and Weight	Bypass
Guard	Hydraulic Damper
Limit/ Proximity Switch	

Applicable Standards
To BS EN 12334-2001 (BS 5153:1974 (1991))
BS EN 1074 - Pt.3 : 2000
Flanges and drilling to BS EN1092-2: PN25

Materials of Construction	
Description	Material
Body	Ductile Iron BS EN 1563 EN-GJS-500/7
Disk	Ductile Iron BS EN 1563 EN-GJS-500/7
Cover	Ductile Iron BS EN 1563 EN-GJS-500/7
Face/Seat	Gunmetal BS EN 1982 CC491K
Hinge Pin	Stainless Steel BS EN 10088 Gr. 1.4057
Bearings	Bronze
Gasket	EPDM WRc listed
Fasteners	Zinc Plated Carbon Steel
Coating	Internal and external, applied blue epoxy to WIS 4-52-01 Class B DFT 250 microns



Glenfield Valves Ltd, Glenfield Works, Queens Drive, Kilmarnock, Scotland, KA1 3XF
 Tel: +44 (0) 1563 521150 Fax: +44 (0) 1563 545616 www.glenfield.co.uk

A member of the **AVR** group of companies



SPECIFICATIONS

Series 641/03 (5000) PN 25, Swing Check Valve, 350mm and above

Component List

- | | |
|--------------|--------------|
| 1. Body | 5. Hinge Pin |
| 2. Disk | 6. Gaskets |
| 3. Cover | 7. Bearings |
| 4. Face/Seat | |

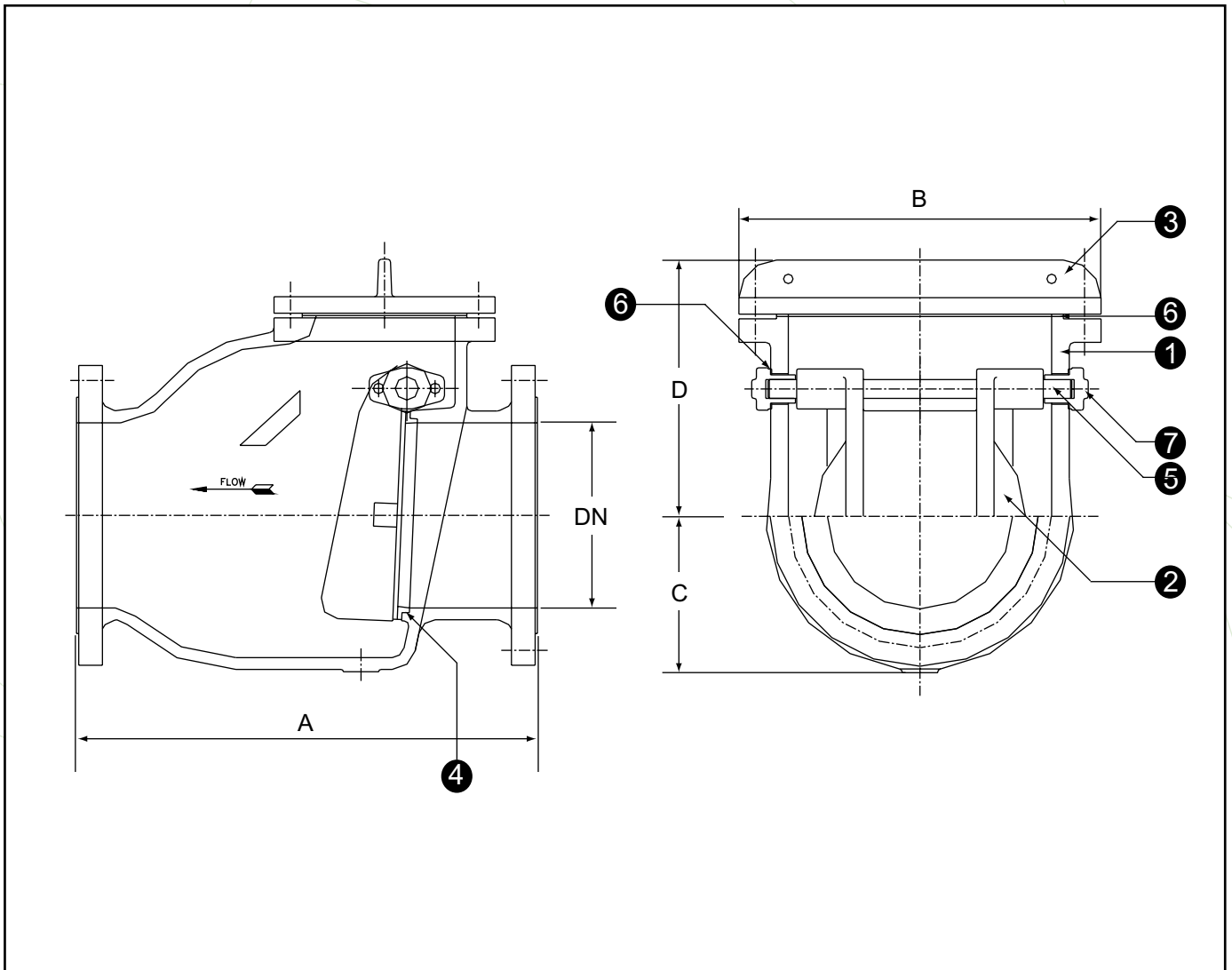

Dimensions (mm)

Ref. No.	DN	A	B	C	D	Approx Weight (kg)
641-0350-03700000	350	787	690	294	430	465
641-0400-03700000	400	914	690	294	482	610
641-0450-03700000	450	965	838	410	515	790
641-0500-03700000	500	1067	815	429	535	1080
641-0600-03700000	600	1219	915	448	610	1510
641-0700-03700000	700	1200	1070	520	750	2480
641-0800-03700000	800	1400	1196	590	816	3100
641-0900-03700000	900	1400	1196	590	816	3300
641-1000-03700000	1000	1750	1440	725	1019	3630