

# Glenfield

Water engineers to the world

Series 756 PN 25 Bronze Seat, Resilient Seal Butterfly Valves, 700mm -1400mm

Use	
For water and neutral liquids to max. 70°C	

Tests	
Hydraulic tests:	Body: 1.5 x PN Seat: 1.1 x PN

Optional Extras	
Electric or Hydraulic actuation	Lockable Disk
Alternative materials	Special Drilling

Applicable Standards
Standards: BS EN 593 (ex BS 5155)
Flanges: BS EN 1092-2:PN 16
Face to Face: BS EN 558-1 Series 14
For Series 13 (Short Face to Face) please contact our sales department

Materials of Construction	
Description	Material
Body	Ductile Iron BS EN 1563 Gr.500/7
Door	Ductile Iron BS EN 1563 Gr.500/7
Retaining Ring	Ductile Iron BS EN 1563 Gr.500/7
End Plate	Carbon Steel BS 4360 Gr 43A
Main Shaft	Stainless Steel BS EN 10088 Gr 1.4057
Stub Shaft	Stainless Steel BS EN 10088 Gr 1.4057
Bushes	Glacier DU(B)
Body Seat Ring	Gunmetal BS EN 1982 CC491K
Seal Housing	Gunmetal BS EN 1982 CC491K
Key	Key Steel BS 4235
Resilient Seal	EPDM WRc listed
Capscrews to Retaining Ring	Stainless Steel BS 6105 Gr A2-70
Worm Gearbox	Miscellaneous
Coating	Internal and external blue two pack epoxy to WIS 4-52-01 Class B DFT 250 microns

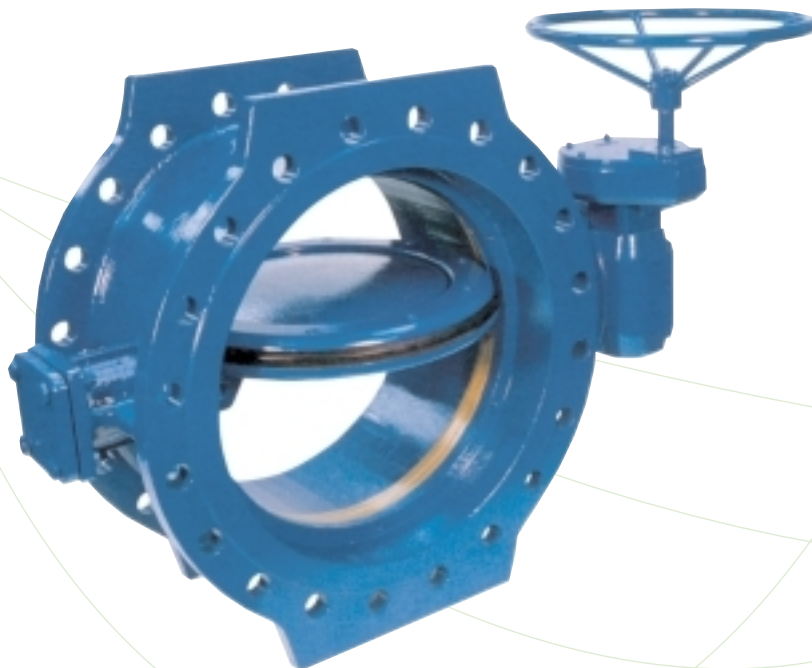

Glenfield Valves Ltd, Glenfield Works, Queens Drive, Kilmarnock, Scotland, KA1 3XF

Tel: +44 (0) 1563 521150 Fax: +44 (0) 1563 545616 www.glenfield.co.uk

A member of the **AVR** group of companies



# SPECIFICATIONS

Series 756 PN 25 Bronze Seat, Resilient Seal Butterfly Valves, 700mm - 1400mm

## Component List

- |                   |                                 |
|-------------------|---------------------------------|
| 1. Body           | 7. Bushes                       |
| 2. Door           | 8. Seal Housing                 |
| 3. Retaining Ring | 9. Key                          |
| 4. End Plate      | 10. Resilient Seal              |
| 5. Main Shaft     | 11. Capscrews to retaining ring |
| 6. Stub Shaft     | 12. Body Seat Ring              |

Enlarged View of Seat Area

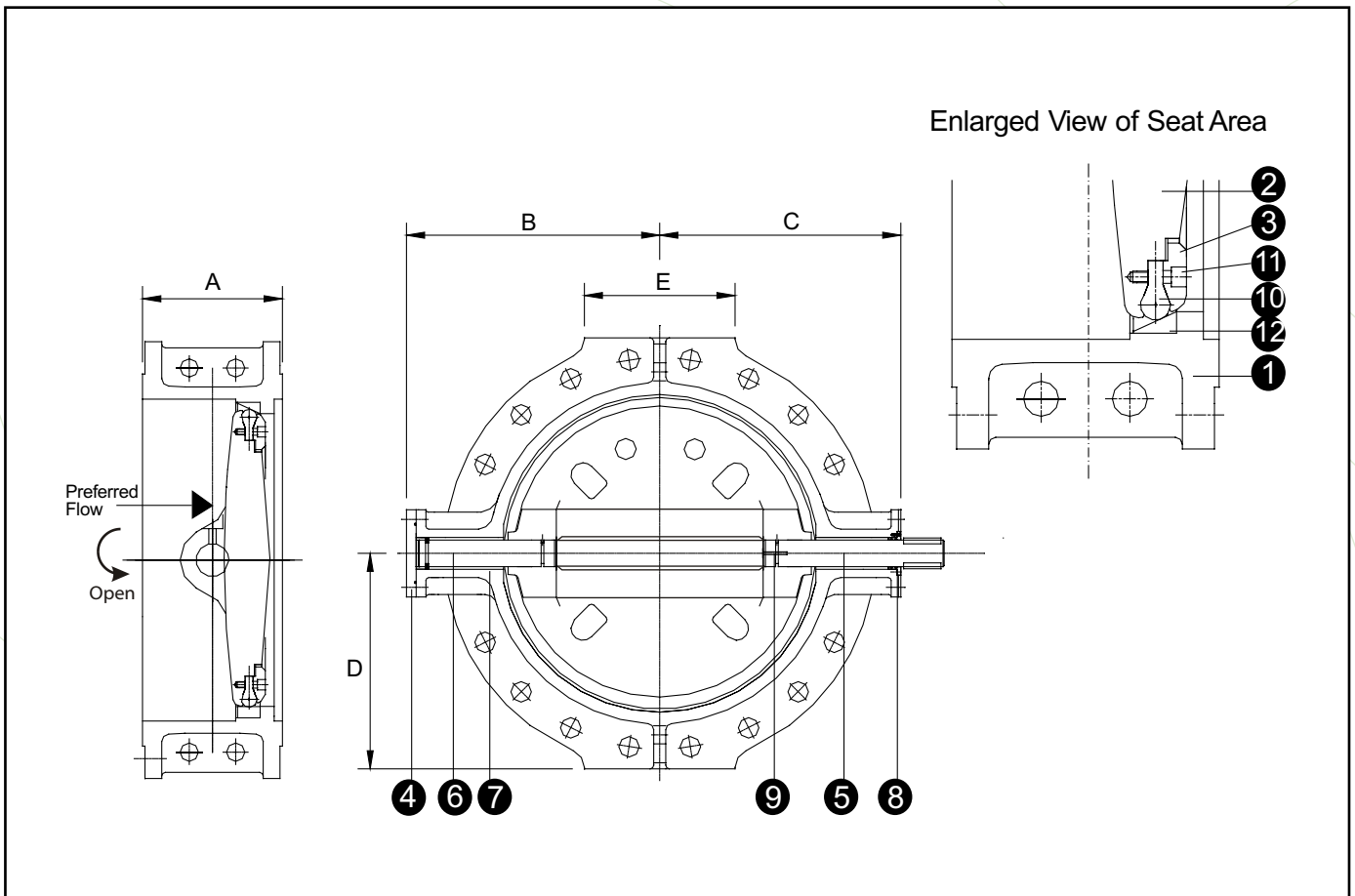

## Dimensions (mm)

Ref Nos.	DN	A	B	C	D	E	Approx Weight (kg)
756-0700-12400002	700	430	545	530	455	320	960
756-0800-12400002	800	470	620	600	513	350	1420
756-0900-12400002	900	510	690	670	563	400	1530
756-1000-12400002	1000	550	770	750	628	450	1970
756-1100-12400002	1100	590	820	800	678	490	2550
756-1200-12400002	1200	630	855	835	743	520	3040
756-1400-12400002	1400	710	1044	1024	843	650	4750