

Glenfield

Water engineers to the world

Series 29 KS (1119) PN 16 Underground Fire Hydrant 80mm

Use		Materials of Construction	
For water and neutral liquids to max. 70°C		Description	Material
		Stem Cap	Grey Cast Iron BS EN 1561 EN-GJL-250
		Stem	Stainless Steel BS EN 10088 Gr. 1.4401 (316)
		Gland Assembly	Ductile Iron BS EN 1563 EN-GJS-500/7 with Bush Nylon 6.6 and 4 O rings, NBR WN70/2
		Bonnet	Ductile Iron BS EN 1563 EN-GJS-500/7
		Fastenings	Hex Head Stainless Steel Grade A4 (316)
		Thrust Collar	DZR Brass BS EN 12164, CW602N
		Body/bonnet Seal	NBR WM70/2
		Body	Ductile Iron BS EN 1563 EN-GJS-500/7
		Stopper Assembly (fixed or loose)	Ductile Iron BS EN 1563 EN-GJS-500/7 encapsulated in EPDM, complete with DZR Brass wedge nut to BS EN 12164 CW602N.
		Body Seat	Integral
		Auto-Frost Valve Assembly	Nylon 6.6 body and plunger with NBR WN70/2 O-rings and Stainless Steel spring to DIN 17224
		Dust Cap	Cast Iron
		Outlet	Gunmetal BS EN 1982 CC491K
		Coating	Internal and external, electrostatically applied blue epoxy to WIS 4-52-01 Class B DFT 300 microns
Tests			
Hydraulic tests: Seat: 1.1 x PN Body: 1.5 x PN			
Optional Extras			
Fixed or Loose Stopper PN 25 Version Swept Version (19-989)	Various Outlet Options Include: Instantaneous Dublin Belfast Bayonet Nylon London Round Thread		
Applicable Standards			
BS 750:1984 Type 2 (Screwed--down type with 2 1/2" round thread outlet) Inlet flange universally drilled to BS EN 1092-2 PN 10/16 and to BS Table D/E Kitemarked WRAS approved cert. no. 0210153.			



Glenfield Works, Queens Drive, Kilmarnock, Scotland, KA1 3XF
Tel: +44 (0) 1563 521150 Fax: +44 (0) 1563 545616 www.glenfield.co.uk

Glenfield Valves Ltd, A member of the **AVR** group of companies



SPECIFICATIONS

Series 29 KS (1119) PN 16 Underground Fire Hydrant 80mm

Component List

- | | |
|---------------------|-------------------------------|
| 1. Stem Cap | 8. Body |
| 2. Stem | 9. Stopper Assembly |
| 3. Gland Assembly | 10. Body Seat |
| 4. Bonnet | 11. Auto-Frost Valve Assembly |
| 5. Fasteners | 12. Dust Cap |
| 6. Thrust Collar | 13. Outlet |
| 7. Body/Bonnet Seal | |

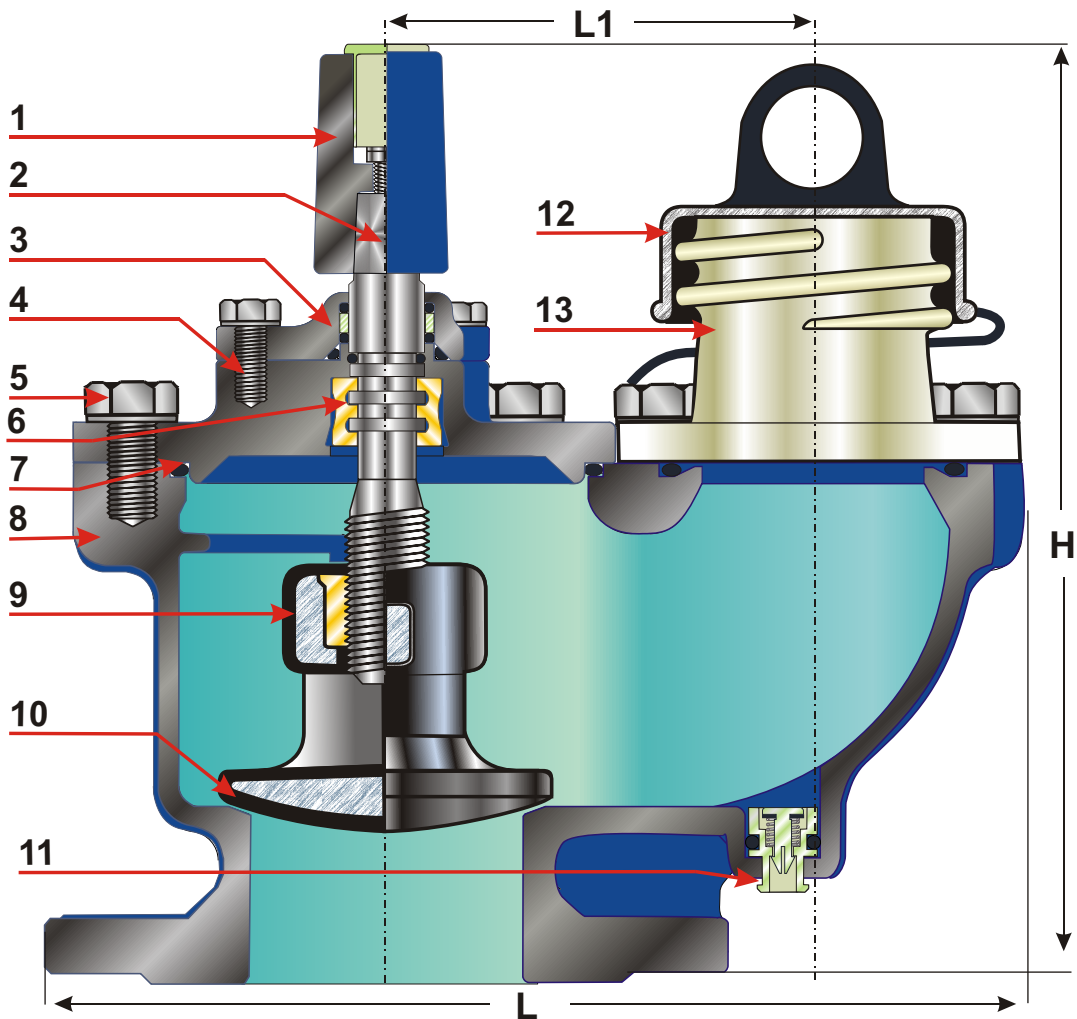

Dimensions (mm)

Ref. No.	DN	L	H	L1	Approx Weight (kg)
29-188-521112001	80	286	274	125	14.3